

SS4-A Multi-Spectrum™ Electro-Optical Digital Fire Detector

SS4-A



FEATURES

- Multi-Spectrum™: senses ultraviolet, visible and wide band infrared
- Built-In test for optical "through the lens" testing
- False alarm immunity
- Detects hydrocarbon and non-hydrocarbon based fires
- Wide field-of-view and solar-blind
- Adjustable detector sensitivity
- Microprocessor based algorithms: FirePic™, and Tri-Mode Plot™
- Wide temperature range of operation
- Compatible with standard approved fire alarm panels
- Explosion-Proof housing
- Time programmable alarm verification

APPLICATIONS INCLUDE:

- Offshore Exploration & Production
- Petrochemical Facilities and Refineries
- Co-Generation Plants
- Aircraft hangers
- Silane Gas Storage
- Gas Turbines & Power Plants
- Gas Compressor Stations

The model SS4-A represents the world's pre-eminent technology for Electro-Optical Flame Detectors. This Multi-Spectrum detector senses radiant energy in the ultraviolet (UV), visible, and wide band infrared (IR) spectrum. The radiant energy from all types of flaming fires will alert the detector to their presence.

The field of view is the widest in the industry with a 120-degree cone of vision. This means more hazard area can be covered by each detector. Greater sensitivity also increases the volume covered by each detector, up to four times more than some other detectors.

Using sophisticated microprocessor signal processing algorithms with complete spectrum information, a high degree of immunity to false alarms from arc welding, corona discharge and other common UV sources are achieved.

OPERATION

The model SS4 operates from standard 24 Volt DC power and interfaces to approved fire alarm panels. When power is applied, a self-test is performed and the fault relay resets to show no faults. The detector then begins searching for the radiant energy patterns of a fire. The front LEDs blink every ten seconds to indicate power is on.

The continuous spectral data stream of information from the sensor array is analyzed by the microprocessor. On Alarm, the detector activates the alarm relay and stores all of the pre-fire spectral data from the sensor array in non-volatile memory for retrieval and evaluation. This Fire Pic™ data can be used to postulate the cause of the fire.

As part of the FS2000™ System, the SS4-A detector communicates with CM1-A Controller via a four wire bi-directional RS-485 FireBus™.

Tri-Mode Plot Shown on Computer Display

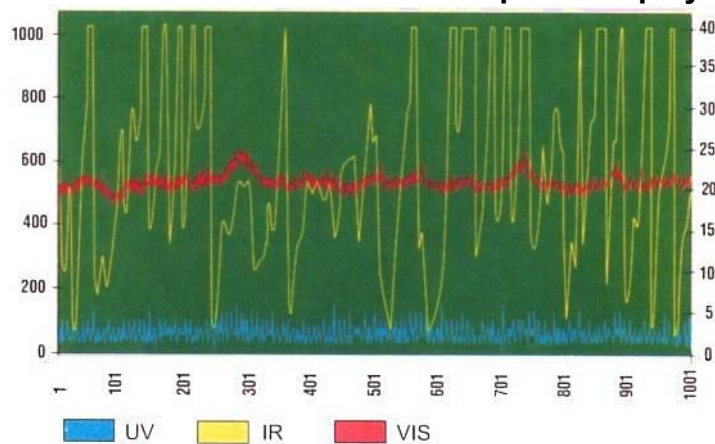

WORLD LEADER IN ELECTRO-OPTICAL FIRE DETECTION



ISO 9001

Copyright 2000 All Rights Reserved

FM, CSA, CSFM & CENELEC Approved

Maximum Sensitivity

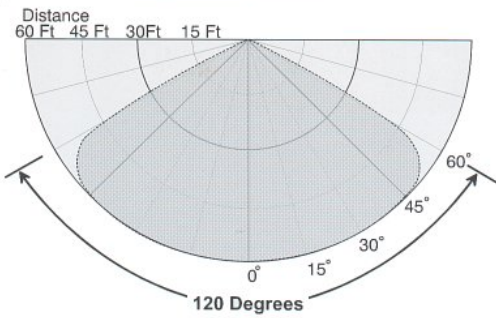

Field of View, Horizontal and Vertical Sensitivity to 1 sq. ft. Gasoline Pan Fire

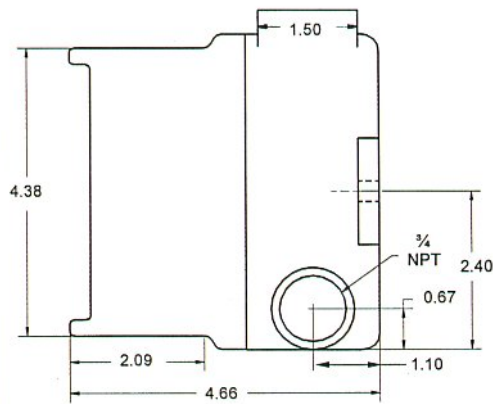

Model SS4 - Side View

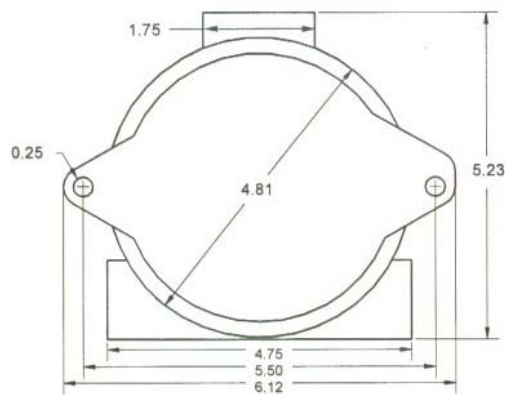

Model SS4 - Back View

SPECIFICATIONS

Sensitivity	Adjustable between 60 ft., 45 ft., 30 ft., & 15 ft. to a 1 sq. ft. Gasoline fire
Response Time	2-5 seconds to 1 sq. ft. of gasoline fire at 60 ft.
Field of View	120 degrees cone of vision (60 degrees from on axis)
Spectral Sensitivity	Ultraviolet: 185 to 260 nanometers Wide Band Infrared: 0.7 to 3.5 micrometers Visible: 400 to 700 nanometers
Input Power	24 VDC nominal (20.5 to 34 VDC)
Power Consumption	56 mA normal operation, typical 75 MA alarm condition, typical
Relay Outputs	Fire relay: NO & NC contacts Latching/Non-Latching, switch selectable Verification relay: NO & NC contacts Adjustable time from 0 – 30 seconds Fault relay: NO & NC contacts Relay contact ratings: 0.5 A at 120 VAC, 1.0 A at 24 VDC
Operating Temperature	- 40 to + 185° F - 40 to + 85° C
Humidity Range	10 to 90% RH, non-condensing
Weight	approximately 3.8 pounds
Housing	Copper-free aluminum (less than 0.4%) polyester TGIC (Mil Spec) powder coated NEMA 3 & 4 weatherproof, tamper resistant with integral dual 3/4 " NPT conduit openings Stainless steel housing available
Electrical Classification	Explosion-Proof Class I, Div. 1 & 2, Groups B, C, & D Class II, Div. 1 & 2, Groups E, F, & G Class III.
Vibration	Meets or exceeds Mill Spec 810C Method 524.2, Curve AW
Mounting	Swivel bracket assembly

ORDERING INFORMATION

SS4-A	Electro-Optical Detector
SM2	Heavy-duty Swivel Mount
FT2045	Explosion-proof Test Lamp
MA420-4	4-20 mA current Module
CM1-A	Wall-mount Controller

Dimensions are in inches
Specification is subject to change without notice

FIRE SENTRY CORPORATION

593 Apollo Street, Brea, California 92821 USA
Tel: (714) 671-1100 Fax: (714) 671-5821
E-Mail: sales@firesentry.com
Web page: firesentry.com