

Directional, Single Tone Industrial Air Horn

*EFFECTIVE OUTDOOR COVERAGE OF UP TO 3.0 KILOMETERS



- Ideal for outdoor Industrial applications
- Single tone, 311 Hz fundamental frequency, engineered to produce full harmonic contents up to 12 octaves which greatly enhance warning effectiveness.
- Horn is energy efficient with hermetically sealed diaphragm assembly which operates on a side range of pressure without tuning or adjustment.
- Horn construction: High strength aluminum casting, stainless steel diaphragm discs and fasteners.

* Signal will produce a sound pressure level of approximately 70 dB @ 3 km in calm, cool conditions without topographical interference. Signal strength at distance can vary dramatically depending on environmental and geographical conditions. Please consult factory for more detailed information.

Control:	Manual, solenoid or combination valve
SPL (Loudness) on Total: Operating Medium: Air Consumption:	140 ± 1 dBA @ 1 meter Air, nitrogen, CO ₂ , 1/2" NPT inlet 11 L/Sec [24 SCFM] @ 7 bar [100 PSIG]
Audibility: Fundamental Frequency: Tone (Musical Note):	3.0 km on still air 311 Hz ± 10 Hz E ^b [E-flat]
Operating Pressure: Operating Temperature:	3 – 10 bar [50 – 150 PSI] -40°C to +85°C [-40°F to +185°F]
Finish: Degree of Protection:	Primed and painted red alkyd enamel IP 54
Basic Dimension: Net Weight:	432x230x229mm [17x8x9"] 3.2 kg [7 lbs]

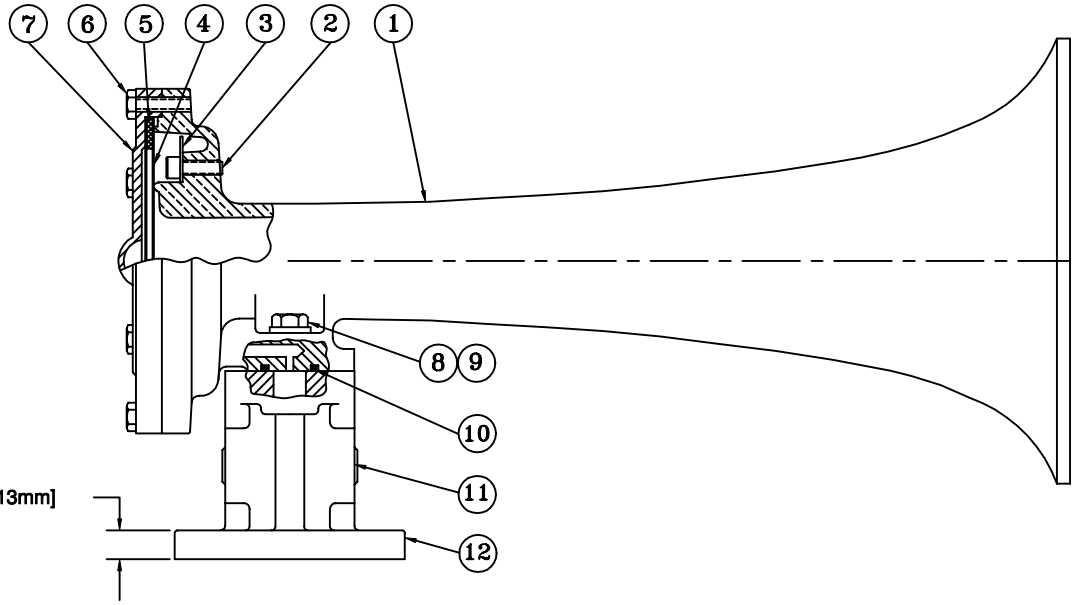
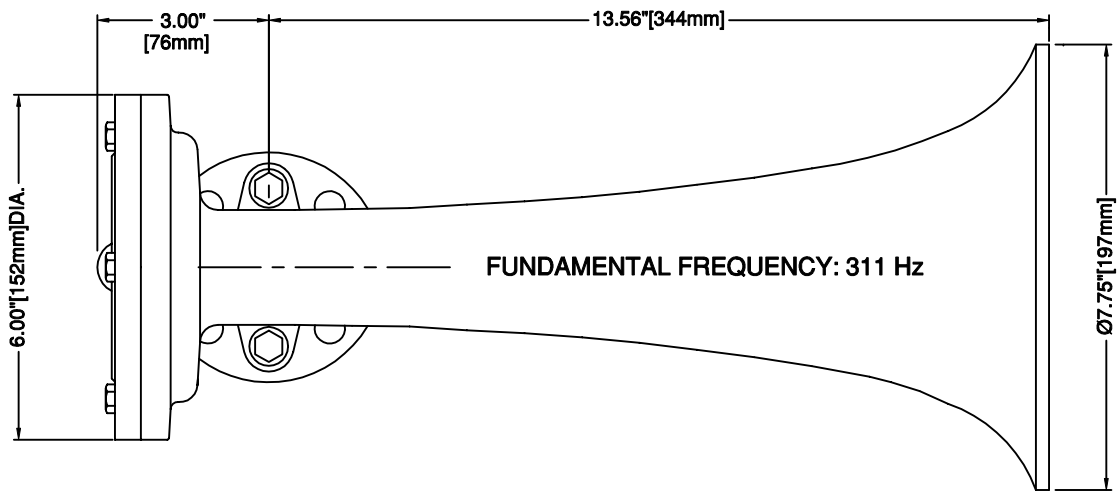

REVISIONS			
REV	DESCRIPTION	DATE (YR-MO-DA)	APPROVED
1	SUPERSEDES DWG. No. WH-30154	95-02-27	J. W. C.

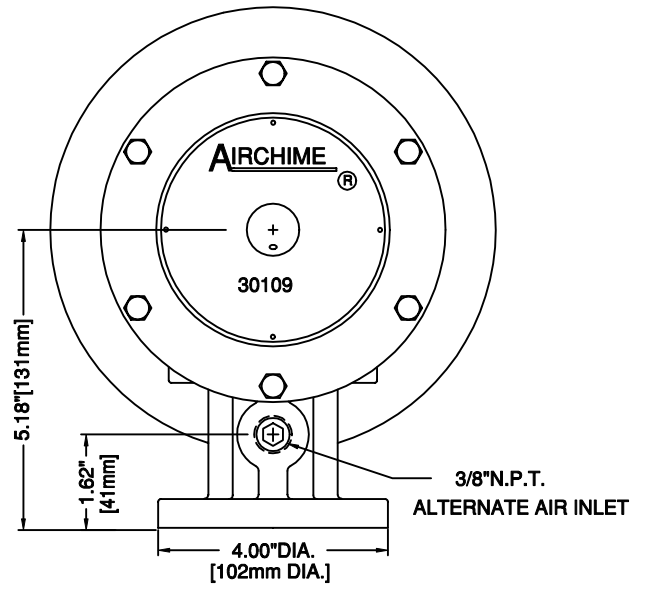
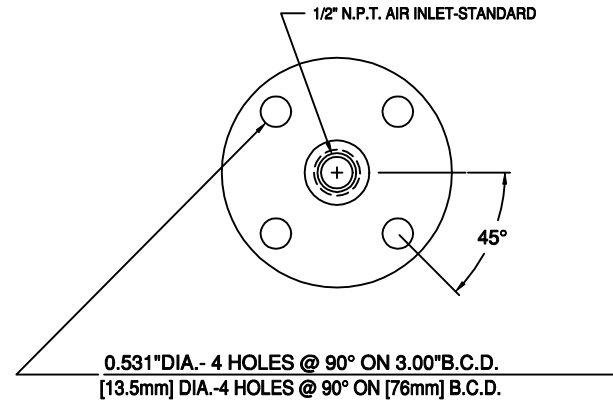

REF	PART	DESCRIPTION	MATERIAL	SPECIFICATION	QTY
1	30101	BELL BODY No. 1	DIE CAST ALUMINUM	ASTM-B26-65	1
2	30144	SOCKET HD. CAP SCREW	STAINLESS STEEL	ASTM F594	3
3	30143	DIFFUSER	STAINLESS STEEL	UNS-S30400	1
4	30111	DIAPHRAGM DISC	STAINLESS STEEL	UNS-S30100	2
5	30112	CUSHION RING	SILICONE RUBBER	ASTM D2000	1
6	30110	HEX HEAD CAP SCREW	STAINLESS STEEL	ASTM F593C	6
7	30109	DIAPHRAGM CAP	DIE CAST ALUMINUM	ASTM-B26-65	1
8	30119	HEX HEAD CAP SCREW	STAINLESS STEEL	ASTM F593C	2
9	30122	LOCKWASHER	STAINLESS STEEL	ASA B27.1	2
10	30211	O RING	BUNA N	ML STD 417 SB	1
11	20914	PIPE PLUG 3/8" N.P.T.	ALLOY STEEL	ASA B18.8	2
12	30117	BASE-SINGLE TONE	CAST ALUMINUM	UNS A03562	1

CONFIDENTIAL

INFORMATION CONTAINED HEREIN IS CONFIDENTIAL, IT IS THE PROPERTY OF AIRCHIME MFG. CO. LTD., IT IS TO BE USED SOLELY FOR THE PURPOSE PROVIDED, AND IT IS NOT TO BE DISCLOSED TO OTHERS WITHOUT THE PRIOR WRITTEN CONSENT OF AIRCHIME MANUFACTURING COMPANY LIMITED.

© CopyRight Airchime Mfg. Co. Ltd.

CONTRACT NUMBER

CONTRACTOR

DRAWN BY: *J. W. P.* DATE (YR-MO-DA) 80-02-27

CHECKER: *R. E. S.* ENGINEER *R. E. S.*

DRAWING APPROVAL *R. E. S.*

TYPE OF DRAWING: **ASSEMBLY**

AIRCHIME MANUFACTURING CO. LTD.
LANGLEY, B.C. CANADA
V4W 3S8

MODEL K-1
SINGLE BELL WHISTLE

SIZE **A** NSCM 36575

30231

SCALE: NONE UNIT WT: 6.8 LBS SHEET: 1 OF 1